

PT. MAXI TIGA INDONESIA

MTI

PT. MAXI TIGA INDONESIA

GATE VALVE



**“Maxi Valve for Maximum
Performance”**

www.maxi-valve.co.id

ABOUT US

PT MAXI TIGA INDONESIA is an API 6D, API 600, ISO 9001, ISO 45001, ISO 14001 certified company specializing in manufacturing industrial valves including ball valves, gate valves, globe valves, check valves, plug valves and butterfly valves in carbon steel, stainless steel, duplex stainless and alloy materials. Our products conform to the latest industry standards in accordance to ANSI, ASME and API.

MTI today has over 3000 square feet of manufacturing facilities. Through its conviction to provide only the finest quality products and services to match the need of our customers, MTI has now established itself as a serious player in the valve business.

We consider product quality and customer satisfaction as our highest priority. We look forward to new customer relationships by providing value, quality, customer service, honesty, integrity and the commitment to maintain product consistency with each and every order.

MISSION STATEMENT

We at MTI commit to taking ACTION:

- Adopt the latest technology to take the product quality to the next level;
- Consistently provide on-time services to our customers;
- Train and develop talented people with strong work ethics to deliver effective performance;
- Improve and enhance engineering designs to ensure product performance;
- Optimize management systems and increase productivity;
- Never forget our customer and employee needs.



GATEVALVE

TABLE OF INDEX	PAGE
Introduction, <i>Features</i>	3
Scope of Products	4
Overview Gate Valve (Bolted Bonnet)	5
Dimensions and Weights	6
<i>Class 150 (PN 20)</i>	6
<i>Class 300(PN 50)</i>	7
<i>Class 600(PN 100)</i>	8
<i>Class 900(PN 150)</i>	9
<i>Class 1500(PN 250)</i>	10
Overview Gate Valve (Pressure Seal Bonnet)	11
Dimensions and Weights	12
<i>Class 900 (PN 150)</i>	12
<i>Class 1500 (PN 250)</i>	13
<i>Class 2500 (PN 420)</i>	14
<i>Overview Special Type (Extent Bonnet)</i>	15
Valve Figure Number, <i>How To Order</i>	16-18

INTRODUCTION

MTI cast gate valves are offered by default with flexible gate, renewable seat, rising stem and non-rising hand wheel. It plays the role of pipe opening and closing ultimately through the rotation of the hand wheel to drive the lifting of gate.

Bolted bonnet, pressure bonnet, bellow seal bonnet, high/low temperature extended bonnet and ISO 15848 fugitive emission designed valves are available upon different request of services.

Forged body can also be provided upon special request.

Design of Disc

Cast steel gate valve are made with flexible wedge by default, solid wedge will be provided only upon request.

Design of Seat

Renewable seat and non-renewable seat are optional, the default for WCB body is seal welded seat, and body overlay seat against other valve body material.

Design of Body -Bonnet Connection

Bolted bonnet is normally applied on CL150~CL900, body seal is defaulted by gasket and RTJ ring. Pressure seal bonnet is applied on CL1500~CL2500 with pressure seal ring for body seal.

Design of Packing

By default graphite packing is used, PTFE packing can be used on corrosive media. API 600 fugitive emission packing will be used upon request.

Design of Backseat

Renewable back seat is applied on all carbon steel and low alloy steel valve, however, body back seat is only applied for stainless steel valve.

Design of Actuation

Hand wheel and gear box are normally designed for cast gate valve based on different size and pressure rating; Electric, pneumatic or Chain wheel operation can be provided upon request.



GATE VALVE

SCOPE OF PRODUCTS

Gate Valve

Legends:

A –Available in Bolt Bonnet

B–Available in Pressure Seal Bonnet

C–Not Usually Required

Size in/mm	Class 150 PN 20	Class 300 PN 50	Class 600 PN 100	Class 900 PN 150	Class 1500 PN 250	Class 2500 PN 420
2 50	A	A	A	A, B	A, B	A, B
2 1/2 65	A	A	A	A, B	A, B	A, B
3 80	A	A	A	A, B	A, B	A, B
4 100	A, C	A, C	A, C	A, B, C	A, B, C	A, B, C
6 150	A	A	A	A, B	A, B	A, B
8 200	A	A	A	A, B	A, B	A, B
10 250	A	A	A	A, B	A, B	A, B
12 300	A	A	A	A, B	A, B	A, B
14 350	A	A	A	A, B	A, B	C
16 400	A	A	A	A, B	A, B	C
18 450	A	A	A	A, B	A, B	C
20 500	A	A	A	A, B	A, B	C
22 550	A	A	A	A, B, C	A, B, C	C
24 600	A	A	A	A, B	A, B	C
26 650	A	A	A	A, B	A, B	
28 700	A	A	A	A, B	A, B	
30 750	A	A	A	A, B	A, B	
32 800	A	A	A	A, B		
34 850	A	A	A	A, B		
36 900	A	A	A	A, B		
38 950	A, E	A, E	A	A, B		
40 1000	A, E	A, E	A	A, B		
42 1050	A, E	A, E	A	A, B		
48 1200	A, E	A, E	A	A, B		

1. The sizes listed above are normal diameters. Contact our sales representative if any other dimensions are requested.

GATE VALVE

OVERVIEW (Bolted Bonnet)

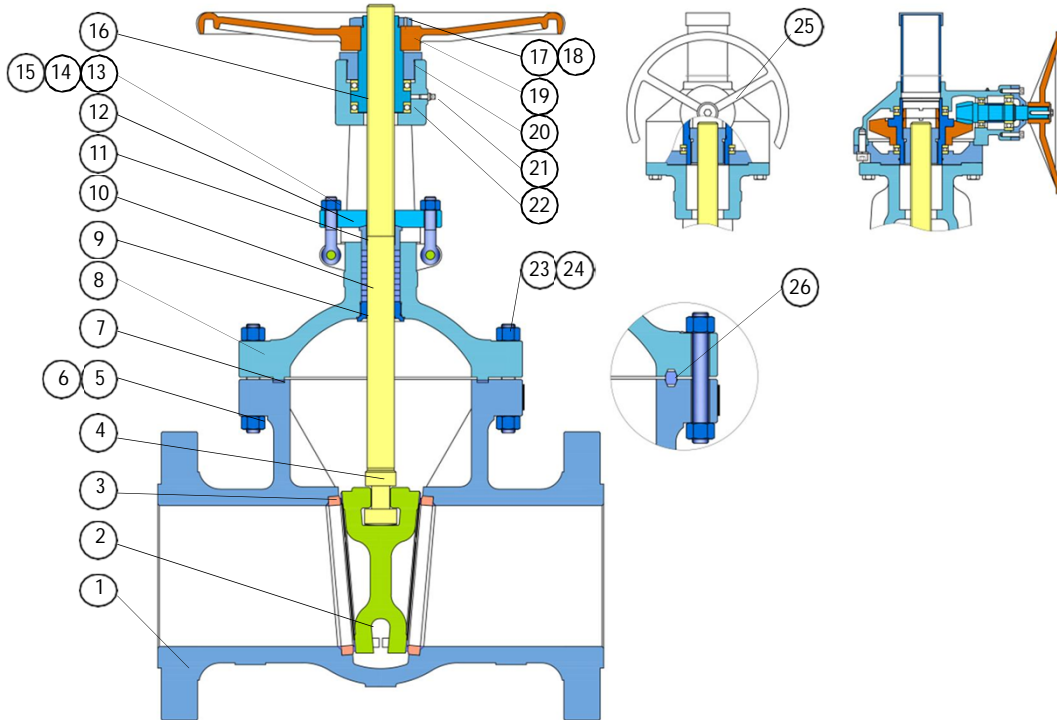

Part List

① Body	⑦ Gasket	⑬ Eye Bolt	⑲ Handwheel	⑳ Gear
② Wedge	⑧ Bonnet	⑭ Nut	㉑ Bearing Nut	㉒ Octagonal Ring
③ Seat	⑨ Backseat	⑮ Pin	㉓ Lubricating Nipple	
④ Stem	⑩ Packing	⑯ Stem Nut	㉔ Bearing	
⑤ Stud	⑪ Gland	⑰ Handwheel Nut	㉕ Stud	
⑥ Nut	⑫ Gland Flange	⑱ Screw	㉖ Nut	

Standards

Design & Manufacture API 600, ASME B16.34, MSS SP-144

Face-to-face ASME B16.10

End Dimension ASME B16.5 (RF, RTJ),
ASME B16.47 (RF, RTJ)
ASME B16.25 (BW)

Test & Inspection API 598

Typical Materials

Body, Bonnet, Disc	(Casting): A216 WCB, A351 CF3, CF8, CF3M, CF8M, A995 4A, 5A, A352 LCB, LCC, LC2 (Forging): A105, A350 LF2, LF3, LF5, A182 F304, F304L, F316, F316L, F51, F53, F5, F11, F22, F91, Monel, Inconel, Hastelloy
Stem	A182 F6a, F304, F304L, F316, F316L, F51, F53, F55 Monel, Inconel, Hastelloy

GATE VALVE

DIMENSIONS AND WEIGHTS (Bolted Bonnet)

ASME CLASS 150 (PN 20)

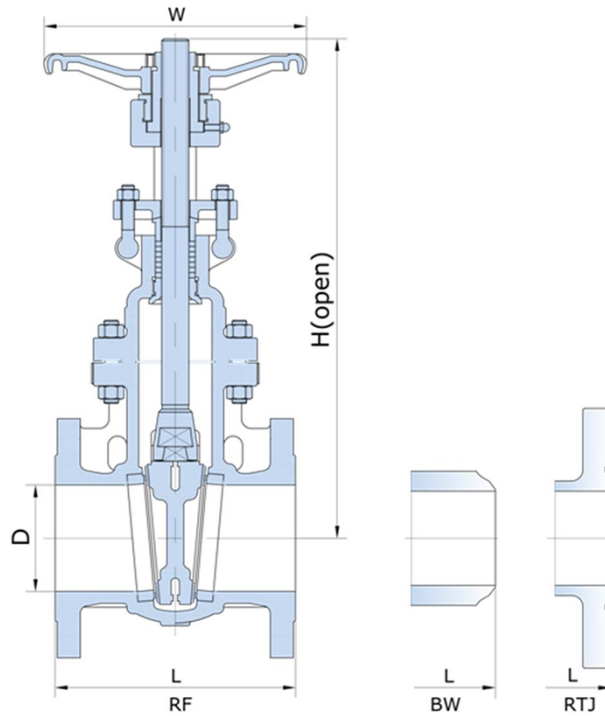

ASME CLASS 150 (PN 20)

Size in/mm	D	L			H	W	Weight
		RF	RTJ	BW			RF/BW (lb/kg)
2	2	7	7.5	8.5	15.87	7.87	40/33
50	51	178	191	216	403	200	18/15
2½	2.5	7.5	8	9.5	18.9	7.87	55/40
65	64	190	203	241	480	200	25/18
3	3	8	8.5	11.12	20.12	9.84	70/57
80	76	203	216	283	511	250	32/26
4	4	9	9.5	12	23.7	11	110/90
100	100	229	242	305	602	280	50/41
5	5	10	10.5	15	30.91	11.81	143/130
125	125	254	267	381	785	300	65/59
6	6	10.5	11	15.88	34.84	11.81	170/152
150	150	267	280	403	885	300	77/69
8	8	11.5	12	16.5	38.5	13.78	267/238
200	203	292	305	419	978	350	121/108
10	10	13	13.5	18	46.93	15.75	392/344
250	250	330	343	457	1192	400	178/156
12	12	14	14.5	19.75	55	17.72	584/546
300	305	356	369	502	1397	450	265/248
14	14	15	15.5	22.5	62.32	19.69	800/727
350	337	381	394	572	1583	500	363/330
16	15.24	16	16.5	24	67.76	23.62	1020/934
400	387	406	419	610	1721	600	463/424
18	17.24	17	17.5	26	76.77	26.77	1368/1293
450	438	432	445	660	1950	680	621/587
20	19.25	18	18.5	28	85.35	28.35	1744/1656
500	489	457	470	711	2168	720	792/752
22	21.26	20	20.5	30	92.52	29.53	2313/2093
550	540	508	521	762	2350	750	1050/950
24	23.27	20	20.5	32	105	29.53	2621/2520
600	591	508	521	813	2668	750	1190/1144
26	25.24	22	-	34	-	-	3350/3458
650	641	559	-	864	-	-	1521/1570
28	27.24	24	-	36	-	-	4048/4185
700	692	610	-	914	-	-	1838/1900
30	29.25	24	-	36	-	-	24980/6608
750	743	610	-	914	-	-	261/3000

The dimension and weights are for reference only and subject to change without notice.

1. For more dimensional information, please contact our sales representative.
2. "W" on above schematic is the diameter for hand wheel, the one without dimension on the table above is defaulted by gear operation.

GATE VALVE

DIMENSIONS AND WEIGHTS (Bolted Bonnet)

ASME CLASS 300 (PN 50)

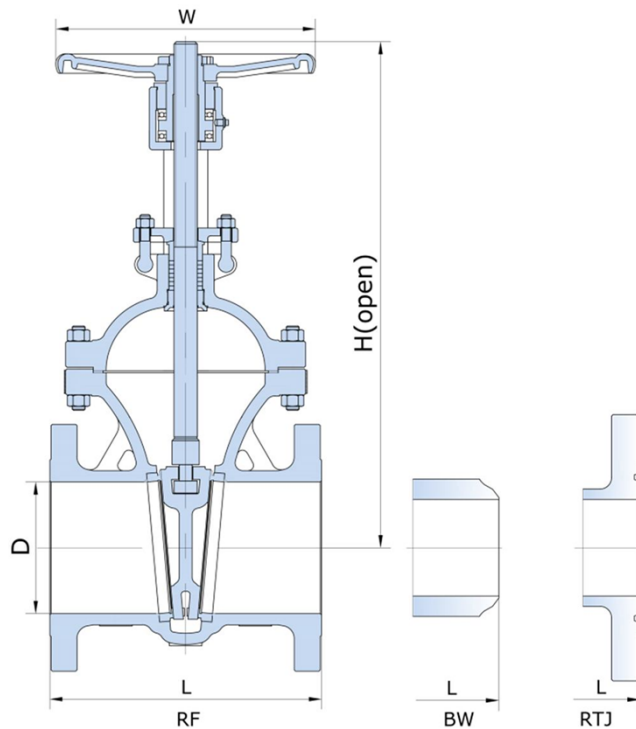

ASME CLASS 300 (PN 50)

Size in/mm	D	L			H	W	Weight
		RF	RTJ	BW			RF/BW (lb/kg)
2	2	8.5	9.13	8.5	17.05	7.87	51/37
50	51	216	232	216	433	200	23/17
2 1/2	2.5	9.5	10.12	9.5	18.54	7.87	77/57
65	64	241	257	241	471	200	35/26
3	3	11.1	11.73	11.1	21.06	9.84	110/86
80	76	282	298	282	535	250	50/39
4	4	12	12.64	12	24.7	11	156/117
100	100	305	321	305	627	280	71/53
5	5	15	15.63	15	28.15	11.81	256/200
125	125	381	397	381	715	300	116/91
6	6	15.87	16.5	15.87	32.44	13.78	317/249
150	150	403	419	403	824	350	144/113
8	8	16.5	17.13	16.5	39.53	15.75	460/361
200	203	419	435	419	1004	400	209/164
10	10	18	18.62	18	49.61	17.72	709/564
250	250	457	473	457	1260	450	322/256
12	12	19.76	20.39	19.76	58.27	19.7	1062/859
300	305	502	518	502	1480	500	482/390
14	14	30	30.63	30	63.19	-	1504/1244
350	337	762	778	762	1605	-	683/565
16	15.24	33	33.62	33	71.06	-	2093/1773
400	387	838	854	838	1805	-	950/805
18	17	36	36.61	36	78.54	-	2522/2126
450	432	914	930	914	1995	-	1145/965
20	19	39	39.76	39	94.69	-	3601/3106
500	483	991	1010	991	2405	-	1635/1410
22	21.8	43	43.86	43	100.4	-	5176/4626
550	553	1092	1114	1092	2550	-	2350/2100
24	23	45	45.87	45	104.33	-	5859/5077
600	584	1143	1165	1143	2650	-	2660/2305
26	25	49	50	49	116.14	-	6806/5595
650	635	1245	1270	1245	2950	-	3090/2540
28	27	53	54	53	122.05	-	7291/6002
700	686	1346	1371	1346	3100	-	3310/2725
30	29	55	56	55	126	-	7919/6729
750	736	1397	1422	1397	3200	-	3595/3055

The dimension and weights are for reference only and subject to change without notice.

1. For more dimensional information, please contact our sales representative.
2. "W" on above schematic is the diameter for hand wheel, the one without dimension on the table above is defaulted by gear operation.



GATE VALVE

DIMENSIONS AND WEIGHTS (Bolted Bonnet)

ASME CLASS 600 (PN 100)

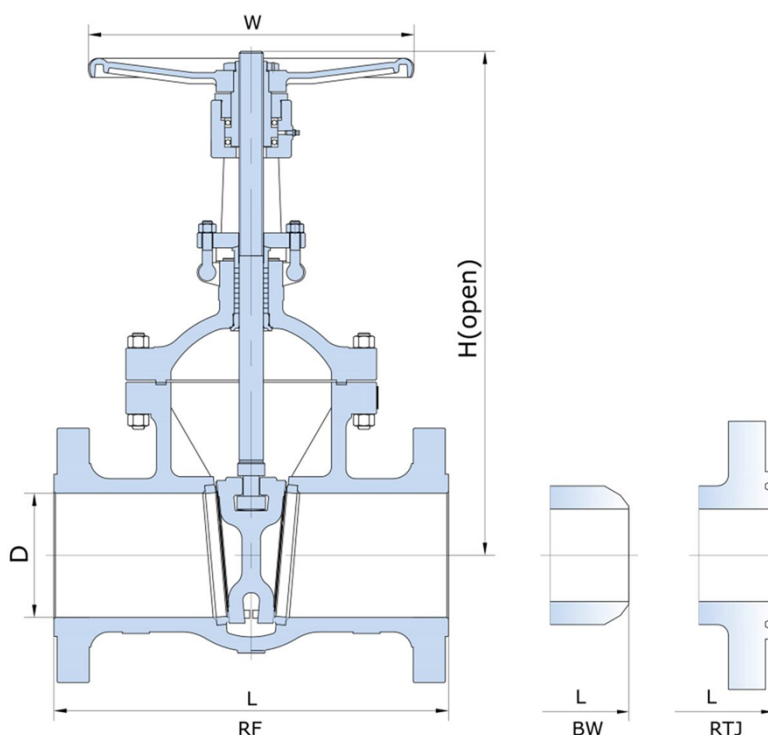

ASME CLASS 600 (PN 100)

Size in/mm	D	L			H	W	Weight	
		RF	RTJ	BW			RF/BW (lb/kg)	
2	2	11.5	11.63	11.5	16.5	441	79/64	
50	51	292	295	292	418	200	36/29	
2 ½	2.5	13	13.13	13	18.75	551	115/93	
65	64	330	333	330	476	250	52/42	
3	3	14	14.13	14	20.38	617	148/117	
80	76	356	359	356	518	280	67/53	
4	4	17	17.13	17	25.5	661	247/183	
100	100	432	435	432	646	300	112/83	
5	5	20	20.12	20	29.5	881	330/267	
125	125	508	511	508	750	400	150/121	
6	6	22	22.13	22	33	991	374/275	
150	150	559	562	559	840	450	170/125	
8	7.87	26	26.13	26	40.38	1100	866/683	
200	200	660	663	660	1025	500	393/310	
10	9.76	31	31.13	31	48.38	23.62	1344/1040	
250	248	787	790	787	1230	600	610/472	
12	11.73	33	33.13	33	57	23.62	1960/1608	
300	298	838	841	835	1450	600	890/730	
14	12.87	35	35.12	35	62	-	2742/2324	
350	327	889	891	889	1575	-	1245/1055	
16	14.76	39	39.13	39	70.62	-	3370/2731	
400	375	991	994	991	1795	-	1530/1240	
18	16.5	43	43.13	430	76	-	4317/2786	
450	419	1092	1095	1092	1930	-	1960/1625	
20	18.27	47	47.25	47	87	-	5396/4471	
500	464	1194	1200	1194	2210	-	2450/2030	
22	20.12	51	51.38	51	97.24	-	6123/4956	
550	511	1295	1305	1295	2470	-	2780/2250	
24	22	55	55.38	55	101.5	-	6597/5705	
600	559	1397	1407	1397	2580	-	2995/2590	
26	23.74	57	57.5	57	105	-	7654/6289	
650	603	1448	1461	1448	2665	-	3475/2855	
28	25.51	61	61.5	61	109.5	-	8205/6751	
700	648	1549	1562	1594	2780	-	3725/3065	
30	27.36	65	65.5	65	114	-	8910/7489	
750	695	1651	1664	1651	2895	-	4045/3400	

The dimension and weights are for reference only and subject to change without notice.

- For more dimensional information, please contact our sales representative.
- "W" on above schematic is the diameter for hand wheel, the one without dimension on the table above is defaulted by gear operation.



GATE VALVE

DIMENSIONS AND WEIGHTS (Bolt Bonnet)

ASME CLASS 900 (PN 150)

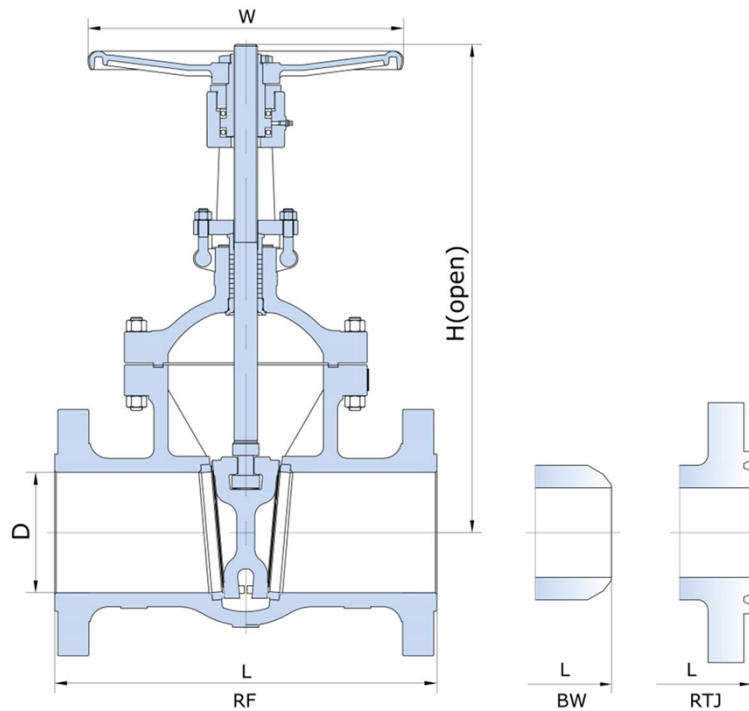

ASME CLASS 900 (PN 150)

Size in/mm	D	L			H	W	Weight
		RF	RTJ	BW			RF/BW (lb/kg)
2	1.87	14.5	14.63	14.5	19.62	7.87	163/119
50	47.5	368	371	368	498	200	74/54
2 ½	2.24	16.5	16.62	16.5	21.5	9.84	222/172
65	57	419	422	419	547	250	101/78
3	2.87	15	15.13	15	22.5	11.81	289/231
80	73	381	384	381	573	300	131/105
4	3.86	18	18.13	18	26.62	17.72	379/297
100	98	457	460	457	678	450	172/135
5	4.76	22	22.13	22	35.5	19.7	615/463
125	121	559	562	559	900	500	276/210
6	5.75	24	24.13	24	38.2	19.7	378/573
150	146	610	613	610	970	500	335/260
8	7.48	29	29.13	29	43.5	23.62	1410/1134
200	190	737	740	737	1103	600	640/515
10	9.37	33	33.13	33	53	-	2423/2026
250	238	838	841	838	1345	-	1100/920
12	11.1	38	38.13	38	60	-	3546/3040
300	282	965	968	965	1525	-	1600/1380
14	12.24	40.5	40.88	40.5	74.5	-	4956/4427
350	311	1029	1039	1029	1900	-	2250/2010
16	14	44.5	44.88	44.5	81	-	6278/5650
400	356	1130	1140	1130	2055	-	2850/2565
18	15.75	48	48.5	48	87	-	6740/5474
450	400	1219	1232	1219	2215	-	3060/2485
20	17.52	52	52.5	52	101	-	8447/7159
500	445	1321	1334	1321	2565	-	3835/3250
24	21	61	61.75	61	104	-	10793/8954
600	533	1549	1568	1549	2640	-	4900/4065

The dimension and weights are for reference only and subject to change without notice.

- For more dimensional information, please contact our sales representative.
- "W" on above schematic is the diameter for hand wheel, the one without dimension on the table above is defaulted by gear operation.



GATE VALVE

DIMENSIONS AND WEIGHTS (Bolted Bonnet)

ASME CLASS 1500 (PN 250)

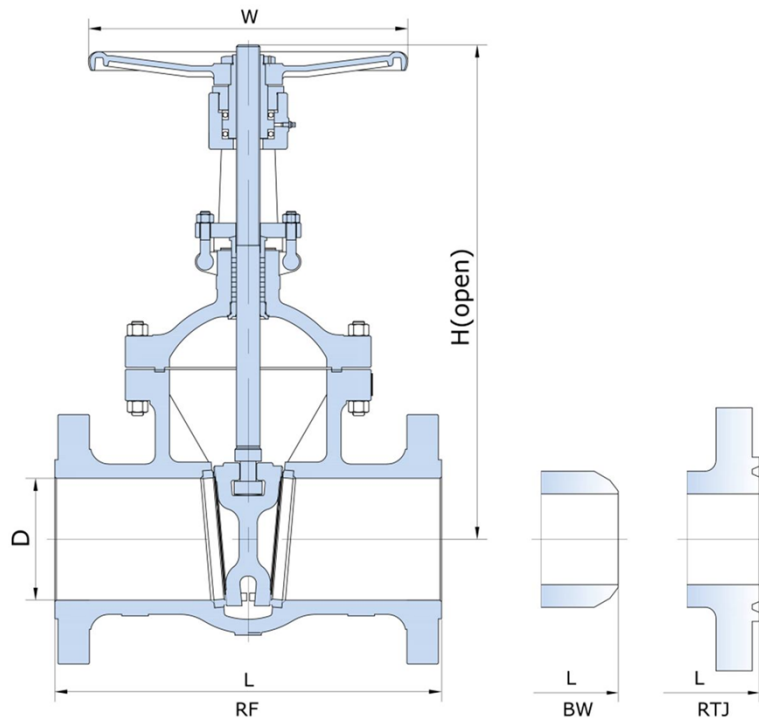

ASME CLASS 1500 (PN 250)

Size in/mm	D	L			H	W	Weight
		RF	RTJ	BW			RF/BW (lb/kg)
2	1.87	14.5	14.61	14.5	24.25	10	256/231
50	47.5	368	371	368	615	250	116/105
2 1/2	2.24	16.5	16.61	16.5	26	12	366/330
65	57	419	422	419	658	300	166/150
3	2.76	18.5	18.62	18.5	30	18	460/414
80	70	470	473	470	760	450	209/188
4	3.58	21.5	21.61	21.5	34.12	20	652/584
100	91	546	549	546	868	500	296/265
5	4.73	26.5	26.61	26.5	38.4	24	958/826
125	111	673	676	673	975	600	435/375
6	5.35	27.75	28	27.75	39.5	24	1123/907
150	136	705	711	705	1005	600	510/412
8	7	32.75	33.15	32.75	45	-	2026/1586
200	178	832	842	832	1145	-	920/760
10	8.74	39	39.41	39	54	-	4207/3610
250	222	991	1001	991	1370	-	1910/1640
12	10.35	44.5	45.12	44.5	61	-	6947/6068
300	263	1130	1146	1130	1650	-	3154/2755
14	11.38	49.5	50.24	49.5	74.88	-	9031/7048
350	289	1259	1276	1259	1900	-	4100/3200
16	13	54.5	55.35	54.5	80.5	-	13656/11674
400	330	1384	1406	1384	2050	-	6200/5300
18	14.61	60.5	61.38	60.5	93.75	-	19747/17775
450	371	1537	1559	1537	2350	-	8965/8070
20	16.38	65.5	66.38	65.5	101.5	-	28855/25969
500	416	1664	1686	1664	2580	-	13100/11790
24	19.61	76.5	77.6	76.5	114.75	-	34934/31443
600	498	1943	1971	1943	2915	-	15860/14275

The dimension and weights are for reference only and subject to change without notice.

1. For more dimensional information, please contact our sales representative.
2. "W" on above schematic is the diameter for hand wheel, the one without dimension on the table above is defaulted by gear operation.

GATE VALVE

OVERVIEW (Pressure Seal Bonnet)

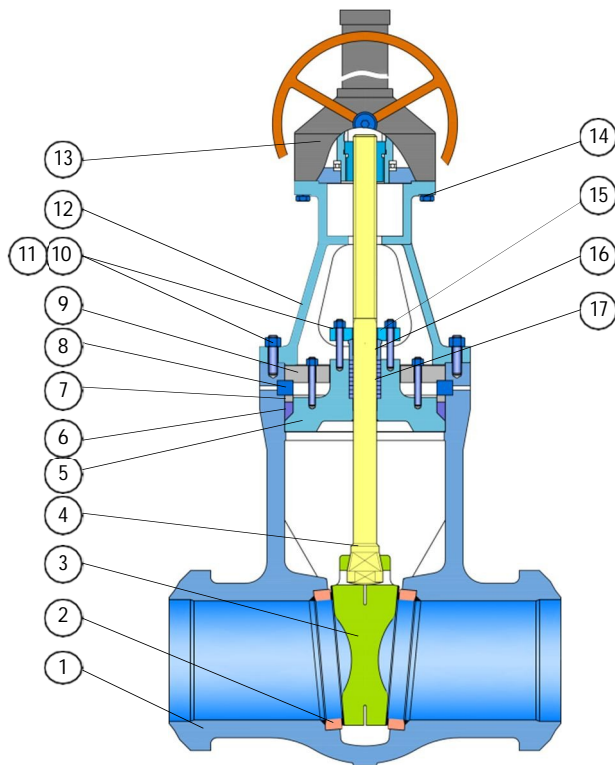

Part List

① Body	⑤ Bonnet	⑨ Push Plate	⑬ Gear
② Seat	⑥ Seal ring	⑩ Stud	⑭ Bolt
③ Wedge	⑦ Push ring	⑪ Nut	⑮ Gland flange
④ Stem	⑧ Split ring	⑫ Yoke	⑯ Gland

Standards

Design & Manufacture	ASME B16.34, MSS SP-144	
Face-to-face	ASME B16.10	
End Dimension	ASME B16.5(RF, RTJ) ASME B16.47(RF, RTJ) ASME B16.25 (BW)	
Test & Inspection	API 598, ASME B16.34	
Typical Materials	Body, Bonnet, Disc	(Casting) A216 WCB, A351 CF3, CF8, CF3M, CF8M, A995 4A, 5A, A352 LCB, LCC, LC (Forging) A105, A350 LF2, LF3, LF5, A182 F304, F304L, F316, F316L, F51, F53, F5, F11, F22, F91, Monel, Inconel, Hastelloy
	Stem	A182 F6a, F304, F304L, F316, F316L, F51, F53, F55 Monel, Inconel, Hastelloy

GATE VALVE

DIMENSIONS AND WEIGHTS (Pressure Seal Bonnet)

ASME CLASS 900 (PN 150)

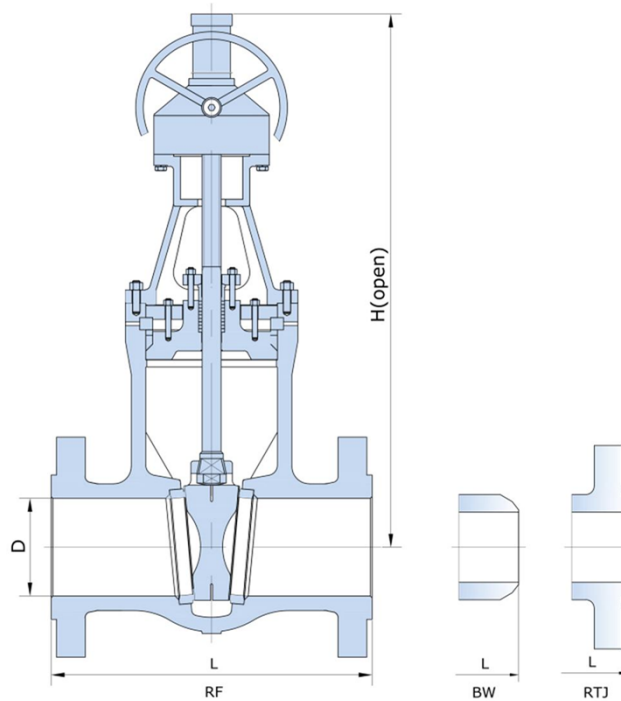

ASME CLASS 900 (PN 150)

Size in/mm	D	L			H	W	Weight
		RF	RTJ	BW			RF/BW (lb/kg)
2	1.87	14.5	14.63	8.5	19.62	7.87	163/119
50	47.5	368	371	216	498	200	74/54
2 ½	2.24	16.5	16.62	10	21.5	9.84	222/172
65	57	419	422	254	547	250	101/78
3	2.87	15	15.13	12	22.5	11.81	289/231
80	73	381	384	305	573	300	131/105
4	3.86	18	18.13	14	26.62	17.72	379/297
100	98	457	460	356	678	450	172/135
5	4.76	22	22.13	17	35.5	19.7	615/463
125	121	559	562	432	900	500	276/210
6	5.75	24	24.13	20	38.2	19.7	378/573
150	146	610	613	508	970	500	335/260
8	7.48	29	29.13	26	43.5	23.62	1410/1134
200	190	737	740	660	1103	600	640/515
10	9.37	33	33.13	31	53	-	2423/2026
250	238	838	841	787	1345	-	1100/920
12	11.1	38	38.13	36	60	-	3546/3040
300	282	965	968	914	1525	-	1600/1380
14	12.24	40.5	40.88	39	74.5	-	4956/4427
350	311	1029	1038	991	1900	-	2250/2010
16	14	44.5	44.88	43	81	-	6278/5650
400	356	1130	1140	1092	2055	-	2850/2565
18	15.75	48	48.5	-	87	-	6740/5474
450	400	1219	1232	-	2215	-	3060/2485
20	17.52	52	52.5	-	101	-	8447/7159
500	445	1321	1334	-	2565	-	3835/3250
24	21	61	61.75	-	104	-	10793/8954
600	533	1549	1568	-	2640	-	4900/4065

The dimension and weights are for reference only and subject to change without notice.

1. For more dimensional information, please contact our sales representative.
2. "W" on above schematic is the diameter for hand wheel, the one without dimension on the table above is defaulted by gear operation.



GATE VALVE

DIMENSIONS AND WEIGHTS (Pressure Seal Bonnet)

ASME CLASS 1500 (PN 250)

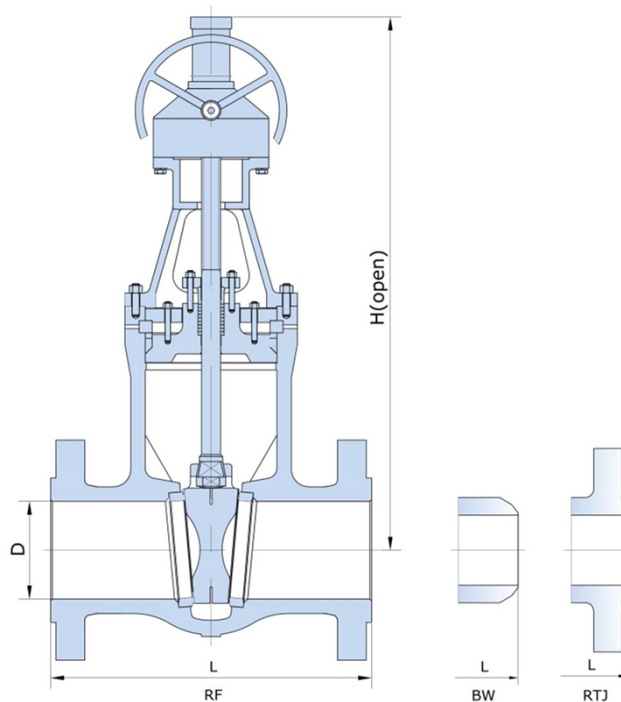

ASME CLASS 1500 (PN 250)

Size in/mm	D	L			H	W	Weight
		RF	RTJ	BW			RF/RTJ (lb/kg)
2	1.87	14.5	14.61	8.5	24.25	10	256/231
50	47.5	368	371	216	615	250	116/105
2 ½	2.24	16.5	16.61	10	26	12	366/330
65	57	419	422	254	658	300	166/150
3	2.76	18.5	18.62	12	30	18	460/414
80	70	470	473	305	760	450	209/188
4	3.58	21.5	21.61	16	34.12	20	652/584
100	91	546	549	406	868	500	296/265
5	4.73	26.5	26.61	19	38.4	24	958/826
125	111	673	676	483	975	600	435/375
6	5.35	27.75	28	22	39.5	24	1123/907
150	136	705	711	559	1005	600	510/412
8	7	32.75	33.15	28	45	-	2026/1586
200	178	832	842	711	1145	-	920/760
10	8.74	39	39.41	34	54	-	4207/3610
250	222	991	1001	864	1370	-	1910/1640
12	10.35	44.5	45.12	39	61	-	6947/6068
300	263	1130	1146	991	1650	-	3154/2755
14	11.38	49.5	50.24	42	74.88	-	9031/7048
350	289	1259	1276	1067	1900	-	4100/3200
16	13	54.5	55.35	47	80.5	-	13656/11674
400	330	1384	1406	1194	2050	-	6200/5300
18	14.61	60.5	61.38	53	93.75	-	19747/17775
450	371	1537	1559	1346	2350	-	8965/8070
20	16.38	65.5	66.38	58	101.5	-	28855/25969
500	416	1664	1686	1473	2580	-	13100/11790
24	19.61	76.5	77.6	-	114.75	-	34934/31443
600	498	1943	1971	-	2915	-	15860/14275

The dimension and weights are for reference only and subject to change without notice.

1. For more dimensional information, please contact our sales representative.
2. "W" on above schematic is the diameter for hand wheel, the one without dimension on the table above is defaulted by gear operation.



GATE VALVE

DIMENSIONS AND WEIGHTS (Pressure Seal Bonnet)

ASME CLASS 2500 (PN 420)

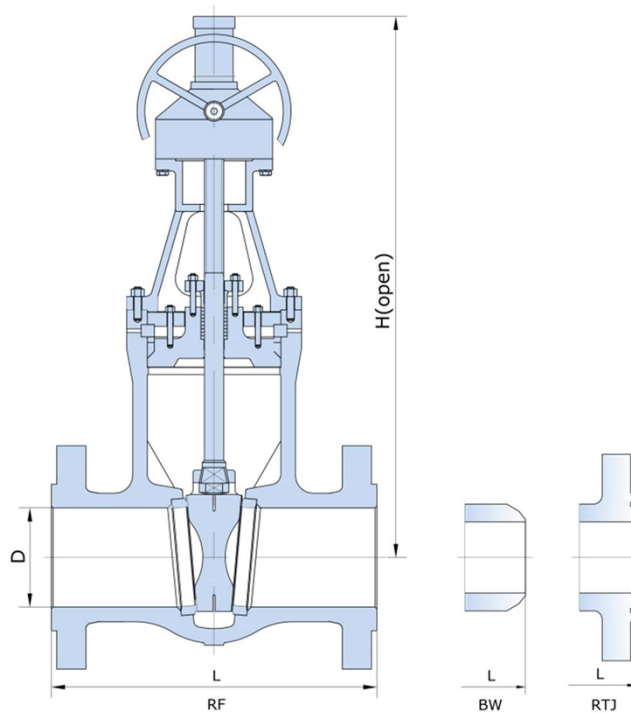

ASME CLASS 2500 (PN 420)

Size <i>in/mm</i>	D	L			H	W	Weight
		RF	RTJ	BW			RF/RTJ <i>(lb/kg)</i>
2	1.5	17.75	17.88	11	23.38	13.78	253/143
50	38	451	454	279	595	350	115/65
2 ½	1.89	20.32	20.56	13	25.6	17.72	300/172
65	48	508	514	330	650	450	136/78
3	2.24	22.75	23	14.5	28	17.72	540/385
80	57	578	584	368	710	450	245/175
4	2.87	26.5	26.88	18	32.25	19.69	1079/826
100	73	673	683	457	820	500	490/375
5	3.62	31.26	31.77	521	43.3	23.62	1476/974
125	92	794	807	33	1100	600	670/430
6	4.37	36	36.5	24	49.62	23.62	1894/1278
150	111	914	927	610	1260	600	860/580
8	5.75	40.25	40.88	30	63.4	-	5396/4405
200	146	1022	1038	762	1610	-	2450/2010
10	7.27	50	50.88	36	81.7	-	10066/8370
250	184	1270	1292	914	2076	-	4570/3800
12	8.62	56	56.88	41	89.8	-	13436/11454
300	219	1422	1444	1041	2281	-	6100/5200
14	9.49	-	-	44	74.88	-	-
350	241	-	-	1118	1900	-	-
16	10.87	-	-	49	80.5	-	-
400	276	-	-	1245	2050	-	-
18	12.24	-	-	55	93.75	-	-
450	311	-	-	1397	2350	-	-

The dimension and weights are for reference only and subject to change without notice.

1. For more dimensional information, please contact our sales representative.
2. "W" on above schematic is the diameter for hand wheel, the one without dimension on the table above is defaulted by gear operation.



GATE VALVE

OVERVIEW (Special Type Cast Steel Gate Valve)

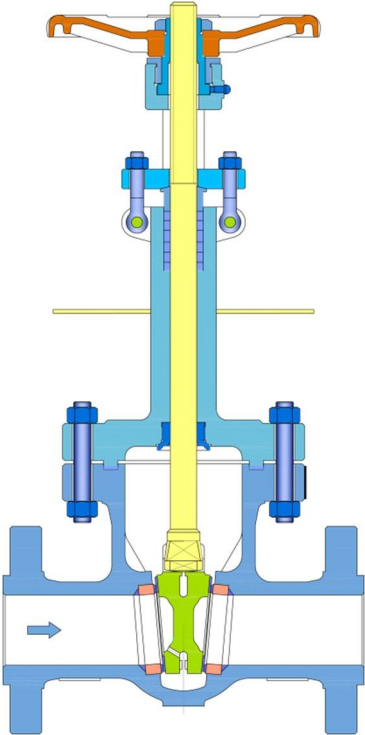
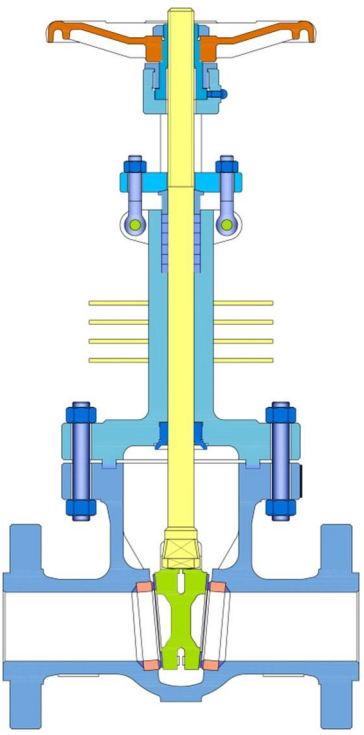
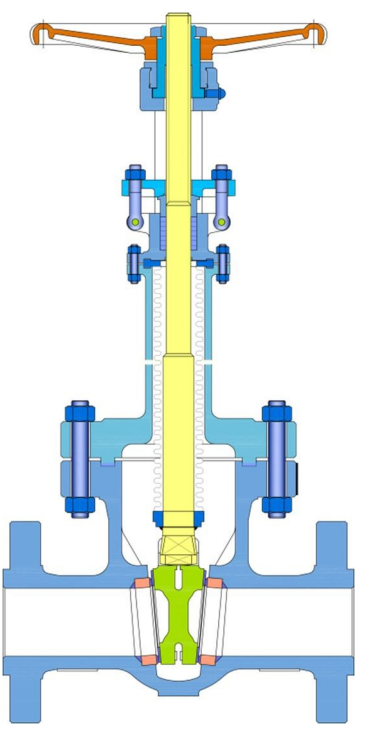
		
<p>Low Temperature Extension</p>	<p>High Temperature Extension</p>	<p>Bellow Seal Extension</p>
<p>Structure characteristics:</p> <ol style="list-style-type: none"> 1. The bonnet are extended for low temperature service, the packing position are raised to avoid the freeze of packing which will affect packing sealing performance; 2. The gate valve shall have relief hole on upstream direction while the pressure may remain in the cavity; 3. Low temperature cold isolation can be an option to prevent cold heat exchange. 	<p>Structure characteristics:</p> <ol style="list-style-type: none"> 1. The high temperature extended structure is mainly to prevent scald operator during operation. 2. The cooling fin can be selected to help heat radiation. 	<p>Structure characteristics:</p> <ol style="list-style-type: none"> 1. Bellow seal extension has the bellow inside of the cavity, the effective compression of the bellows must be greater than the opening stroke of the valve; 2. Bellow seal structure can effectively reduce the leakage of valve stem, the primary seal is for bellows and secondary seal as a filler.

GATE VALVE

VALVE FIGURE NUMBER

HOW TO ORDER

Nominal Size	Valve Type	Pressure Rating	End Conn.	Construct-ion	Body Material	Trim Material	Seat	O-ring	Operation Mode
A	B	C	D	E	F	G	H	I	J
e.g.									

NPS 6 Class 600, Gate Valve, Flexible wedge, bolt bonnet , Raised Face, WCB body, Trim 5#, Renewable Seat, No O-ring, Handwheel Operated.

Nominal Size

00 Special	02 2 (DN 50)	07 8 RB	19 20 RB	31 32 RB
F1 3/8 (DN 10)	R2 2 RB	08 8 (DN 200)	20 20 (DN 500)	32 32 (DN 800)
F2 1/2 (DN 15)	F6 2 ½ (DN 65)	09 10 RB	21 22 RB	33 34 RB
0R 1/2 RB	3R 2 ½ RB	10 10 (DN 250)	22 22 (DN 550)	34 34 (DN 850)
F3 3/4 (DN 20)	03 3 (DN 80)	11 12 RB	23 24 RB	35 36 RB
R0 3/4 RB	R3 3 RB	12 12 (DN 300)	24 24 (DN 600)	36 36 (DN 900)
01 1 (DN 25)	04 4 (DN 100)	13 14 RB	25 26 RB	37 38 RB
R1 1 RB	R4 4 RB	14 14 (DN 350)	26 26 (DN 650)	38 38 (DN 950)
F4 1 ¼ (DN 32)	05 5 (DN 125)	15 16 RB	27 28 RB	39 40 RB
1R 1 ¼ RB	R5 5 RB	16 16 (DN 400)	28 28 (DN 700)	40 40 (DN 1000)
F5 1 ½ (DN 40)	06 6 (DN 150)	17 18 RB	29 30 RB	41 42 RB
2R 1 ½ RB	R6 6 RB	18 18 (DN 450)	30 30 (DN 750)	... More as such

Valve Type

GA Gate Valve

Pressure Rating

0 Special
1 Class 150
3 Class 300
5 Class 1500
6 Class 600

End Connection

7 Class 2500
9 Class 900
8 Class 800
2 Class 125(PN16)
4 Class 400(PN64)
X Special
R RF Flanged
J RTJ Flanged
F FF Flanged
T Threaded
B Butt-Weld (BW)
S Socket-Weld (SW)

Construction

GA
1 Flexible wedge, Bolted Bonnet
2 Flexible wedge, Welded Bonnet
3 Flexible wedge, Pressure Seal
4 Flexible wedge, Bellow Seal
5 Solid wedge, Bolted Bonnet
6 Solid wedge, Welded Bonnet
7 Solid wedge, Pressure Seal
8 Solid wedge, Bellow Seal

Body Material

X0 Special	M9 A182 F22 CL 3	L5 A350 LF3	S6 A351 CF8M
C1 A105	M0 A217 WC9	L6 A352 LC3	S7 A182 F316L
C2 A216 WCA	E1 A182 F5	L7 A350 LF5	S8 A351 CF3M
C4 A216 WCB	E2 A217 C5	L8 A352 LCB	S9 A182 F347
C6 A216 WCC	E4 A217 C6	L9 A350 LF6	S0 A351 C F8C
M1 A182 F1	E5 A182 F9	LA A350 LF9	D1 A182 F51
M2 A217 WC1	E6 A217 C12	LB A352 LC9	D2 A995 4A
M3 A182 F2	E7 A182 F91	LD A352 LCC	D3 A182 F53
M4 A217 WC4	E8 A217 C12A	S1 A182 F304	D4 A995 5A
M5 A182 F12 CL 2	L1 A350 LF1	S2 A351 CF8	D5 A182 F55
M6 A217 WC5	L2 A352 LCA	S3 A182 F304L	D6 A995 6A
M7 A182 F11 CL 2	L3 A350 LF2	S4 A351 CF3	
M8 A217 WC6	L4 A352 LC2	S5 A182 F316	

Trim Material

00 Special	8. 13Cr/Stellite /13Cr	16 Stellite/Stellite /316	25 F53 /F53 /F53
01 13Cr/13Cr/13Cr	9. Monel/Monel /Monel	17 Stellite /Stellite /347	32 316L/Stellite /316L
02 304/304/304	10 316/316/316	18 Stellite /Stellite /Alloy 20	33 Stellite /Stellite /316L
03 310/310/310	11 Monel/Stellite/Monel	20 304L /304L /304L	34 304L /Stellite /304L
4. Hard 13Cr/Hard 13Cr/13Cr	12 316/Stellite/316	21 316L /316L /316L	35 Stellite /Stellite /304L
5. Stellite /Stellite/13Cr	13 Alloy 20/Alloy 20 /Alloy 20	22 321 /321 /321	
6. 13Cr/Cu-Ni/13Cr	14 Alloy 20/Stellite/Alloy 20	23 F55 /F55/F55	
7. 13Cr/Hard 13Cr /13Cr	15 Stellite /Stellite /304	24 F51/F51 /F51	

GATE VALVE

VALVE FIGURE NUMBER (CONT'D)

HOW TO ORDER

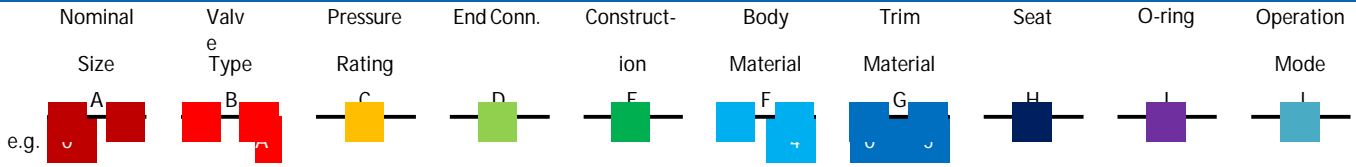

NPS 6 Class 600, Gate Valve, Flexible wedge, bolt bonnet, Raised Face, WCB body, Trim 5#, Renewable Seat, No O-ring, Handwheel Operated.

H Seat

I O-Ring

J Operation

R Renewable Metal

O None

B Bare Stem

N Non Renewable Metal

H Handwheel

G Gear

P Pneumatic

E Electric

C Gear w/ Chain

N. Pneumatic-Hydraulic

O. Solid Handwheel

V Handwheel with locking device

HOW THE FIGURE NUMBER SYSTEM WORKS

Introduction. Figure number system uses a code consisting 14 digits of letters and numbers to represent the specification of a valve of certain specification. Among 14 digits, they are separated into 10 groups identified by letters from A to J. Each group represents a parameter of a valve, together they contain almost all the essential parameters of the valve.

Uses. Using the figure number system to generate a code is easy. Under each group, the code is shown on the left while on the right is the meaning of the code. Start by selecting a code from group A, through group J. If the specification of the valve is not listed, select the code for "Special ". The total length of the figure number shall be exactly 14 digits.

Cautions. It is advised that you have as detailed the specification as possible to generate a figure number, which means eliminating "Specials". If you don't have enough specification or information about the valve you are ordering, or you're not sure how to use the system to generate a figure number, contact one of our sales representatives for help.

Note: MTI reserves the right to make any modifications without notice.



Offshore



Pipeline



Onshore



Refinery



IMPORTANT NOTICE

- All dimensions in inches not listed in standards are converted from millimeters. Weights in lbs (pounds) are converted from kilograms.
- Data listed in the catalog, including dimensions, weights, specifications and other valve related data are intended to provide general information and guidance only.
- MTI Inc. assumes no responsibility for errors or inadequacy relevant to any information provided in this catalog. Any information provided in this catalog is subject to change without notice.



PT. MAXI TIGA INDONESIA

Kawasan Industri Millenium,
Jl. Millenium Blok K1 No. 3,
Tigaraksa – Tangerang,
Banten 15710. Indonesia.

Phone: +62-21-59986484

Email : info@maxi-valve.co.id

www.maxi-valve.co.id